



**WINCHES  
AUSTRALIA**  
Quality Winch Solutions

# Electric Boat Ramp Winch

OWNER'S MANUAL

Serial No.: HWA3500

Revision: 1.1



**QUALITY  
WINCH SOLUTIONS**



THIS PAGE INTENTIONALLY LEFT BLANK

**Proprietary Statement**

© Copyright 2015 HES Winches Australia. All rights reserved. No part of this publication may be reproduced, photocopied, stored on a retrieval system, or transmitted without the express prior written consent of the publisher.

**Disclaimer**

While all care has been taken in the development of this product, no loss of any kind is accepted by HES Winches Australia or its agents arising from the use of this document.

HES Winches Australia makes no representations or warranties with respect to the contents of this document, and specifically disclaims any express or implied warranties or fitness for any particular purpose. Further, HES Winches Australia reserves the right to revise this publication and to make changes to its contents, at any time, without obligation to notify any person or entity of such revisions or changes.

**Trademarks**

HES Winches Australia is a registered trademark. Other trademarks may exist which are not explicitly noted here and they remain registered to the appropriate organizations.

**Revision History**

<b>Revision</b>	<b>Date</b>	<b>Details of Change</b>
1.0	22/06/2015	First Release
1.1	30/04/20108	QR Code & Contact update

# Table of Contents

## Preface

### CHAPTER 1 | Safety

Safety Overview .....	8
Task Safety Process .....	8
Winch Preparation .....	10
Post-Delivery Inspection .....	10
General Checks before Use .....	10
Safe Operation .....	10
Operating Safety Rules .....	10
Before Commencing Work: .....	10
Overheating .....	12
Maintenance Safety .....	12
General Safety Rules .....	12

### CHAPTER 2 | System Overview

General Description .....	13
Specifications .....	13
Options .....	13
Angle Chart .....	14
General Assembly .....	15

### CHAPTER 3 | Installation

Mounting Dimensions .....	17
---------------------------	----

### CHAPTER 4 | Operation

Operator Controls .....	18
Emergency Stop .....	18
Pre Start-up .....	18
Start-up & Operation .....	19
Rope tensioner: .....	19
Radio control: .....	19
Routine Running Checks .....	19
Maintenance .....	19

### Appendix 1 | Warranty Terms and Conditions

## Contact Details



### Head Office

Phone: 1300 946 242  
Mobile: 0477 946 242

Email Sales: [sales@heswinches.com.au](mailto:sales@heswinches.com.au)  
Email Accounts: [accounts@heswinches.com.au](mailto:accounts@heswinches.com.au)

Website: [www.heswinches.com.au](http://www.heswinches.com.au)

Postal: HES Winches Australia  
P.O. Box 688  
Helensvale  
Queensland 4212  
Australia

Address: 27/ 11-17 Cairns Street  
Loganholme  
Queensland 4129  
Australia

## **Preface**

We thank you for choosing a HES Winches Australia product. This document is intended for engineering staff and provides the information necessary to safely operate and maintain the winch system.

This equipment is the result of extensive design and development, and is acknowledged as being a superior product in its category. We congratulate you on your discerning choice and wish you many years of productive service.

Read this manual carefully before operating the equipment or performing any maintenance on the winch systems. It is advised that this manual is kept with the machine at all times as a reference.

For further information please contact HES Winches Australia using the contact details provided on the previous page.

## **Warranty**

HES Winches Australia provides a limited warranty for goods of our own manufacture against defective workmanship and materials which have substantially diminished or are likely to substantially diminish the life or functionality of the goods for a period of twelve months from the date of despatch.

To read the full warranty terms and conditions please refer to appendix 1 located at the rear of this manual.

For any warranty claims please contact HES Winches Australia.

HES Winches Australia reserves the right to request any claimant to supply a copy of the tax invoice as part of the claim.

## CHAPTER 1 | Safety



There are safety risks for people and machinery when working with this winch system. Compliance with safety precautions and risk management standards are vital in mitigating the risk of injury, or damage to the equipment.

Following the safety guidelines will help minimize the risk of injury and ensure a trouble free working life for your winch.

### Safety Overview

Read and follow **all** operating and safety instructions contained in this Owner's Manual.

If you are unable to identify hazards or do not understand the process for use of the RISK MATRIX, stop the job and consult a qualified Occupational Health and Safety consultant.



#### **WARNING**

This symbol has been used throughout this manual and on the equipment to highlight important safety information. Ensure you read and understand the information before embarking on any related task.

### Task Safety Process

Always evaluate the risk factors before starting any work that involves winches.

#### **Plan Your Task**

- List the activities required to undertake the task. Use the Task Planning
- Ensure that the safety processes are understood and communicated to all persons involved with the task.

#### **Identify the Risks**

- Why, when, how what can risk occur?

#### **Assess the Risks**

- Determine the likelihood of a hazard occurring.
- Determine the severity of the consequence.
- Determine the "Action Required" to prevent the hazard from occurring.

#### **Implement Controls**

- Consider how risks can be mitigated by implementing controls such as:
  - Safe work practices and procedures



- Using appropriate equipment or specific people that have experience.
- Establishing barriers, or setting up safety mechanisms such as guards.
- Wearing the correct PPE for the task.

**Are the Risks acceptable?**

- If **NO** – formulate controls to mitigate the risk and re-assess the task.
- If **YES** – Organise the task, maintain controls, communicate instructions clearly, monitor and review progress.

**Monitor and Review**

- Work methodically, check on progress, and communicate.
- Continually monitor the situation by reaffirming:
  - Is the plan being followed?
  - Are controls adequate?
  - Is further assessment required?
  - Have conditions changed?If yes, then stop the task and review the plan.

Figure 1. Task planning chart

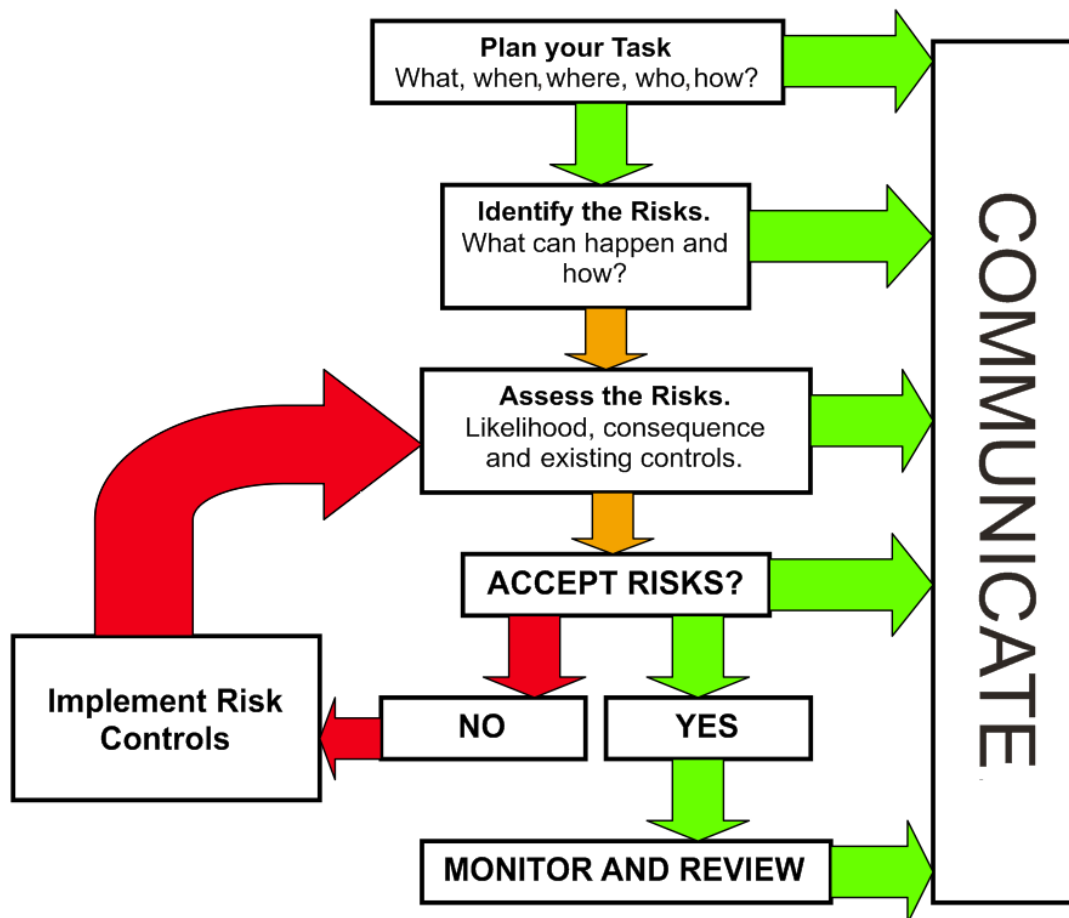

## Winch Preparation

Following delivery of the winch, some basic checks should be conducted to ensure the system can be prepared for safe operation.

### Post-Delivery Inspection

The winch needs to be inspected for any evidence of damage that may have resulted during transport or shipment before it is declared ready for use.

**Note:** If the Owner's Manual for the winch has not been received, immediately contact HES Winches Australia to obtain a copy. Do not inspect, operate or perform maintenance on the winch without having Owner's Manual.

## General Checks before Use

### Winch:

- Visually inspect the winch and all components for any visible damage.
- Inspect all operator controls and ensure they are functional (i.e. levers move as intended, are not bent or missing).
- Inspect all areas for evidence of fluid leaks.

## Safe Operation

In order to ensure the safety of operators and others, it is important that the machine is used appropriately, that design limits are not exceeded and that all risks have been identified and the appropriate risk control measures implemented.

## Operating Safety Rules

To ensure the safe winch operation, the following basic Safety Rules must be understood and complied with at all times.

### Before Commencing Work:

- Action the Daily Operator Checklist.

**Table 1. Daily Operator Checklist**

DAILY CHECKS	
Safety Guarding	Ensure that all safety guards or panels are in good condition and securely fastened.
Operator Controls	Ensure that the operational controls are all functioning as expected
Structure	Ensure that the winch frame and chassis is free from damage such as cracks or corrosion.
Bolts and Fasteners	Ensure that all fasteners (especially those for mounting the machine) are tight, that none are missing or damaged.
Fluids	Ensure that there are no fluid leaks and that all required lubrication has been carried out.

- Ensure all safety instructions are clearly understood and that the operators are familiar with the winch controls.
- Review the working site for hazards and implement the risk control measures.
- Ensure there are no unused ropes, cables, or obstructions around the working area.
- Be aware of vessel/vehicle movement.
- Ensure persons are correctly positioned and know what their involvement and tasks are in relation to the job at hand.
- Ensure that ropes or cables to be used are correctly rated for the task, are not damaged or worn and where appropriate have the necessary test/examination certificates up to date.

**During operations:**

- **Always wear approved, appropriate Personal Protective Equipment (PPE).**
- **Pay attention. Keep alert, and avoid being distracted whilst operating the Winch. Don't stand under a load, or in areas where overhead equipment may swing and cause serious injury.**
- **Keep body parts and clothing away from all moving parts as well as the rope.**
- **Never exceed the maximum load specified for the winch.**
- **Avoid sudden shock or movement of the winch under load and use a slow consistent speed.**
- **Remove the key and shut down the engine whenever the winch is to be left unattended.**
- **Secure any loose items, tools or equipment so that these will not become an operational hazard.**
- **Be aware of non-operating persons in proximity to the equipment, as well as the winch cable or rope.**
- **Always ensure clear communication between the machine operator and other persons involved with the task.**



**WARNING:**

- **Do not place feet or hands in proximity of rotating parts.**
- **Do not smoke (or approach the winch with a naked flame) whilst operating or refuelling.**
- **Do not leave the motor running whilst refuelling.**
- **Do not guide cable with hands or feet.**
- **Do not tie or secure yourself to any part of the winch or equipment.**
- **Do not touch fittings, friction parts or guards whilst operating.**
- **Do not remove safety decals.**
- **Do not remove safety guarding.**

## **Overheating**

The Power Pack is a fully enclosed unit and under extreme conditions may overheat. If the unit is continuously operated under full load for a long period of time, the temperature may rise to an excessive level. Turn off the unit and let it cool down prior to restarting.

## **Maintenance Safety**

The HWA3500 electric boat ramp winch is virtually maintenance free. In the event the HWA3500 requires repair contact HES Winches Australia for further information.



### **WARNING**

Do Not remove the covers of this Winch System. All repairs must be performed by a qualified person only.

Contact HES Winches Australia for further information.

The following sections provide guidelines on how to ensure safety whilst externally servicing the winch equipment.

## **General Safety Rules**

Prior to conducting any work on the structure, the power pack or mechanical components of the winch:

- Ensure the machine has been powered down or isolated
- Wear the appropriate PPE
- Ensure that all loads under tension have been lowered and secured
- Ensure that the correct tools for the work are available
- Keep an extinguisher at hand in case of fire

## CHAPTER 2 | System Overview

### General Description

The HWA3500 electric boat ramp winch is virtually maintenance free. It is driven by a geared transmission providing quiet and safe operation coupled to a purpose built 240 v electric break motor. The drum, frame and guards are fabricated in steel and zinc plated for improved corrosion protection.

### Specifications

Characteristics	Description
GEARED REDUCTION	Sealed for Life
ELECTRIC BRAKE MOTOR	1.1kW single Phase 240v
LOW VOLTAGE PENDANT CONTROL	10M
POWER	Wired Power lead and 3 pin plug (10A)
CABLE	35m, 8mm dia. Aircraft grade
MAX WINCH DRUM STORAGE CAPACITY	70m of 8mm dia.
MAX LINE PULL – FIRST LAYER	1000kg at 4.0m/min
CAPABILITY	3500kg boat and trailer up a 12.5 degree ramp*
AVERAGE LINE SPEED	5.0m/min
WEIGHT	85kg

\*Based on the operation on a firm, smooth surface.

### Options

Characteristics	Description
Wireless Remote Control	-
Rope Tensioner	-
Synthetic Rope	-
Three Phase Electric Break Motor	415V

## Angle Chart

The maximum weight the electric boat ramp winch can haul depends on the angle of the boat ramp.

To determine the safe weight for the angle of your boat ramp, calculate the total weight of your boat and trailer. Use the Angle Chart below in Table 2 to assess the maximum weight to safely haul boat and trailer/trolley against the angle of the ramp.

Table 2. Angle Chart

	ANGLE OF BOAT RAMP IN DEGREES (GRADIENT)						
WINCH MODEL	5° (1:12)	10° (1:6)	12.5° (1:4.5)	15° (1:3.75)	20° (1:2.75)	25° (1:2.1)	30° (1:1.7)
HWA3500.1	7600 kgs	4300 kgs	3500 kgs	3000 kgs	2400 kgs	1900 kgs	1600 kgs

All figures given in the Angle Chart are based on a hard surface such as concrete or steel tracks with bearing steel wheels or rubber tyres.

The total boat and trailer / trolley maximum weight determines the limit of the angle of the ramp.



### CAUTION

Never exceed the safe maximum weight and angle when operating the boat ramp winch.

## General Assembly

Figure 2. General assembly parts identification diagram.  
Reference: HES1204-001

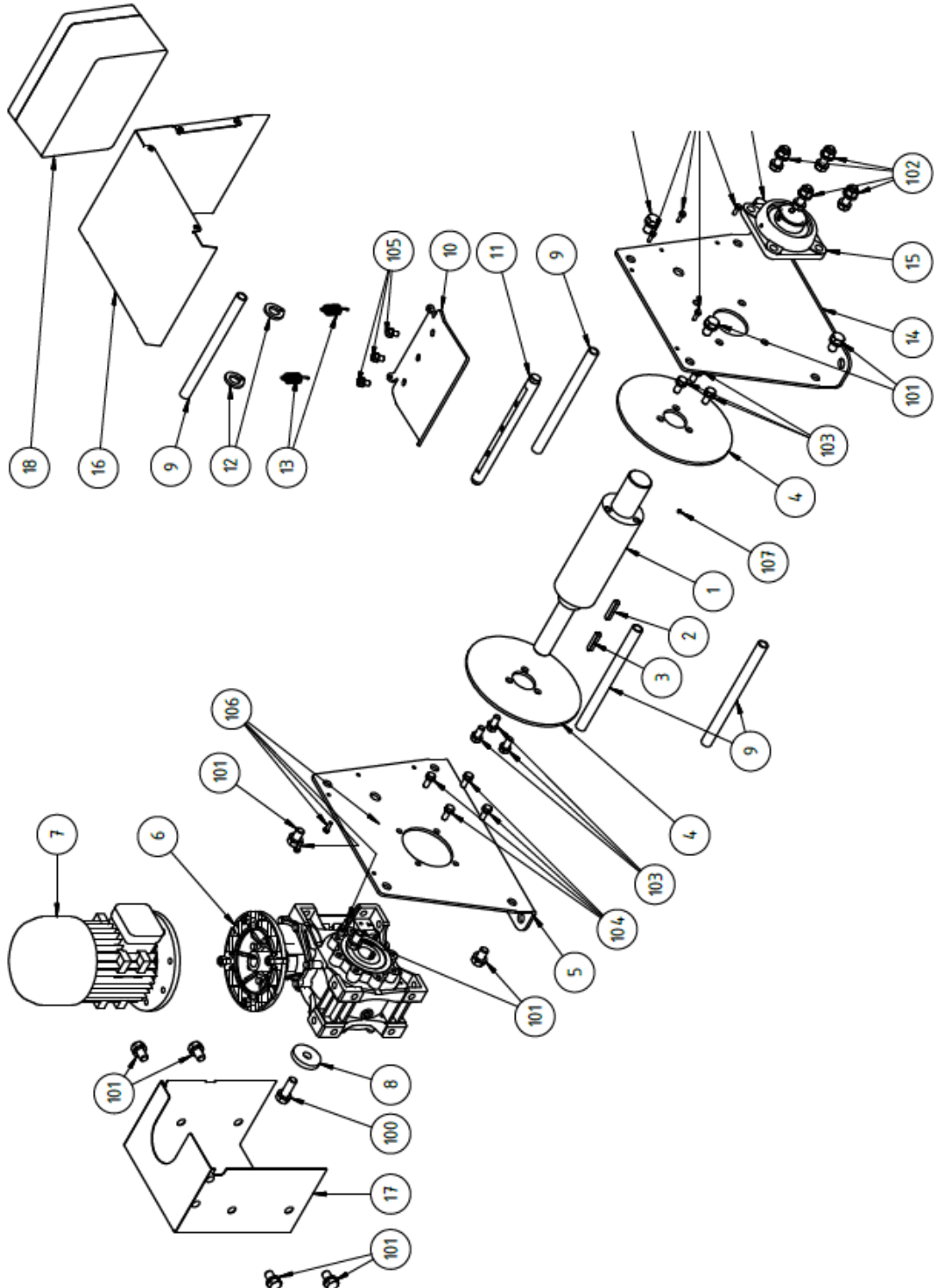

**Table 3. General Assembly Parts Listing**

<b>ASSEMBLY REF: HES1204-001</b>			
<b>No.</b>	<b>Qty.</b>	<b>Description</b>	<b>Part Number</b>
1	1	WINCH DRUM SHAFT	HES1204-102
2	1	10x8x50 LONG KEY	BS 4235-1
3	1	10x8x49 LONG KEY	BS 4235-1
4	2	WINCH CHEEK PLATE	HES1204-103
5	1	WINCH GEARBOX SIDE PLATE	HES1204-100
6	1	MOTOVARIO - GEARBOX	NMRV-P090-HW40 110/1 D90B5
7	1	FIR S.r.l. - SELF BRAKING MOTOR GR 90/B5	2306-2450
8	1	WINCH GEARBOX RETAINING PLATE	HES1204-104
9	4	WINCH FRAME TIE BAR	HES1204-105
10	1	ROPE TENSIONER ARM	HES1204-110
11	1	ROPE TENSIONER PIVOT BAR	HES1204-111
12	2	ROPE TENSIONER SPRING MOUNT	HES1204-112
13	2	EXTENSION SPRING	HES1204-113
14	1	WINCH BEARING SIDE PLATE	HES1204-101
15	1	CBC - FLANGED BEARING HOUSING	UCF210
16	1	WINCH COVER PLATE	HES1204-106
17	1	GEARBOX COVER	HES1204-114
18	1	TERMINAL BOX	HES1204-115
100	1	M16x45 HEX HD BOLT C/W FLAT WASHER	AS1111 - 4.6
101	12	M16x25 HEX HD BOLT C/W FLAT WASHER	AS1111 - 4.6
102	4	M14x45 HEX HD BOLT C/W NUT, FLAT WASHER	AS1110 - 8.8 (22 GRIP)
103	6	M12x25 HEX HD BOLT C/W FLAT WASHER	AS1111 - 4.6
104	4	M10x25 HEX HD BOLT C/W FLAT WASHER	AS1111 - 4.6
105	3	M10x16 HEX HD BOLT C/W FLAT WASHER	AS1111 - 4.6
106	8	M6x20 HEX HD BOLT C/W FLAT WASHER	AS1111 - 4.6
107	1	M6x6 FLAT POINT HEX SOCKET SET SCREW	AS1421



## CHAPTER 3 | Installation

The winch is mounted to the boat ramp via the 4 x 21mm holes, the winch can be mounted to a variety of substrates and the mounting hardware should be matched accordingly.

Once the winch is mounted the power is 10A single phase standard 3 pin connection, the winch comes tested and tagged for your safety.

### Mounting Dimensions

The winches can be mounted through the four (4) mounting holes to the client engineered mounting foundation. The mounting holes located at each corner of the winch chassis.

Figure 3. Winch mounting dimensions.

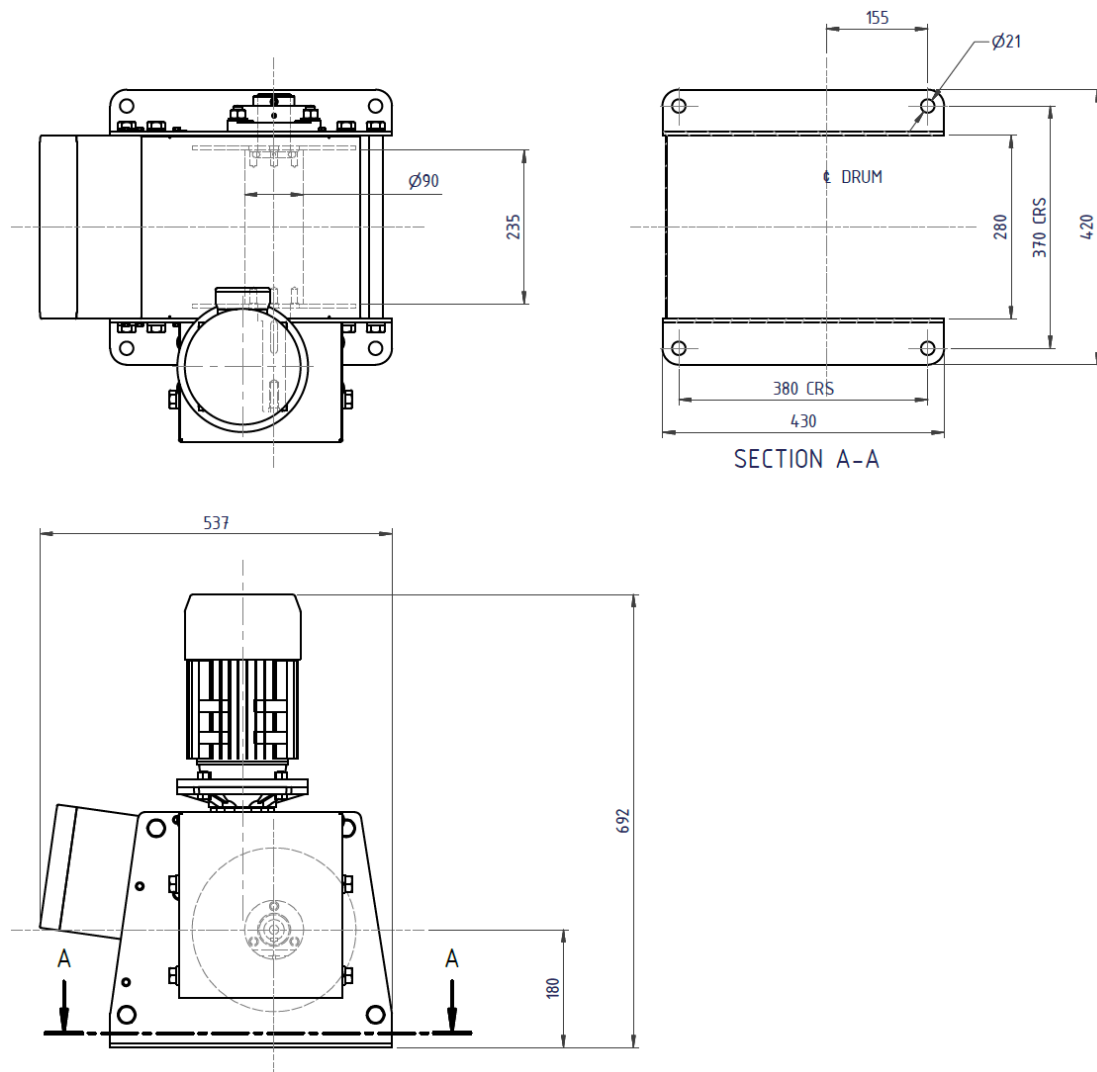

## CHAPTER 4 | Operation

To ensure the safe operation of your HES Winch refer to Task Safety Process on page 8 for further details and how to assess risk. All safety rules, decals and instructions must be understood and complied with at all times.

### Operator Controls

The HWA3500 winch is suited to home boat ramp applications, it can be used single line pull or double reeved.

For single line pull applications refer to Table 2. Angle Chart to determine the safe weight of boat and trailer that can be hauled depending on the angle of the ramp.

The pendant control is plugged in to the matching plug on the winch control box, the pendant is low voltage with a 10m lead.

### Emergency Stop



There are two "EMERGENCY STOP" switches to isolate and stop operation of the winch.

1. Located on the top of the Terminal Box.
2. The pendant controller

The Estop is a good safety feature for once the boat is in position to prevent inadvertent operation.

Use the Emergency Stop button in case of fire or any other danger which poses an immediate risk to personnel or machinery. To activate the stop, press the "EMERGENCY STOP" button all the way in until the button clicks into the down position.

To re-set the emergency stop for winch control can continue, release the "EMERGENCY STOP" button from the down position, twist the button clockwise.

### Pre Start-up

- 1) Before starting the system or commencing operation, refer to the General Checks before Use the on page 10.
- 2) Complete a daily operator checklist prior to use for each winch, refer to the Table 1. Daily Operator Checklist on page 10 for further information.



#### CAUTION

Never start the power unit when a LOCK-OUT tag is present.

## Start-up & Operation

1. Plug in the winch and pendant.
2. Operation is push button up / down.
  - o Hold the button in to operate the winch.
  - o Release the button to stop the winch, the automatic failsafe brake will engage.
3. Use the emergency stop on the pendant control as a safety measure once the boat is in position to prevent inadvertent operation.

### Rope tensioner:

The winch has an optional rope tensioner, the tensioner is spring loaded onto the rope on the winch drum, this assists in feeding the rope on properly and prevents "birds nest" when there is no load on the rope.

### Radio control:

The winch has an optional radio control, the radio control is 433 MHz and works in conjunction with the pendant control, operation is push button up / down, when holding the button in the winch operates, when released the winch stops and the automatic failsafe brake engages. There is an emergency stop on the winch control box.



### CAUTION

Connection to your boat trailer should be matched to the weight being hauled, as a minimum use a 1T D shackle.

## Routine Running Checks

During extended periods of hauling operations, the following checks should be carried out at approximately 2 hourly intervals:

- 1) Check the system and power unit for overheating.
- 2) Listen for any unusual sounds.

## Maintenance

The HWA3500 electric boat ramp winch is virtually maintenance free.

To keep in good working order add grease bearing once every 3 months and lubricate rope with suitable rope grease or lubricant every 3 months.

## Appendix 1 | Warranty Terms and Conditions

### 1. Definition

- 1.1 These terms and conditions between HES Winches Australia (referred to herein as "we" or "us") and the customer (referred to herein as "the customer") shall apply to all orders for "goods" which shall mean materials or parts or machinery and "services" which shall mean labour time in the repair or servicing or installation of goods.
- 1.2 Any contract of sale, order, or quotation made or accepted by or on behalf of us will be subject to these terms and conditions of sale.
- 1.3 Any terms or conditions put forward by the customer, whether in a purchase order, specification or otherwise, will not be binding on us in so far as they purport to amend, annul or augment any of these terms and conditions unless specifically agreed to in writing by us.

### 2. Prices

- 2.1 Prices are for goods ex-store and are subject to alteration without notice. All orders are accepted on the understanding that prices are those ruling at date of despatch unless otherwise agreed in writing by us.
- 2.2 Prices quoted do not include any amount which is payable by us on account of GST as a consequence of any supply made or deemed to be made under or in connection with this agreement ("GST Amount"). The GST Amount must be calculated by multiplying our quoted prices by the prevailing rate of GST and the customer must pay us the GST Amount applicable at the same time and in the same manner as making payment of any consideration on which the GST Amount is calculated.

### 3. Title

- 3.1 We, whilst parting with possession of the goods, shall retain title to (but not risk in) the goods, and title shall only pass to the customer when full payment in cleared funds is received by us. Until this happens:
  - (a) the relationship between us and the customer is a fiduciary one;
  - (b) the customer holds the goods as bailee for us and we hereby authorise the customer to sell the goods in the normal course of business; and
  - (c) the customer shall not assign its right, title or interest in any book debts arising in its favour in respect of its sale of goods.
- 3.2 The customer must pay the proceeds of sale into a separate account pending payment to us. Until payment is received by us in full the customer must store the goods separately pending sale and must keep separate records of sales of goods owned by us.
- 3.3 If payment is overdue we may recover our goods and enter the customer's premises without notice for that purpose. The right to enter is without prejudice to any of our other rights deriving from these terms and conditions. Payment will become due immediately upon the commencement of any act or proceeding in which the customer's solvency is involved.
- 3.4 In the event that the customer uses the goods in some manufacturing or construction process of its own or of a third party, the customer shall hold such part of the proceeds of the manufacturing or construction process as relates to the goods in trust for us. Such part of the proceeds is deemed to equal in dollar terms the amount owing by the customer to us at the time of the receipt of the proceeds.

- 3.5 The risk in the goods will pass to the customer upon the goods being loaded onto transport, except where delivered by our own transport when risk will pass on delivery of the goods to the place designated by the customer.
- 3.6 Insurance and the cost of carriage of the goods ex-store to the place of delivery designated by the customer will be to the customer's account.
- 3.7 When goods are stored by us at the request of or fault of the customer after the goods are ready for despatch, the customer will pay all applicable storage and other charges. Storage will not entitle the customer to postpone payment of any sums due to us.

#### **4. Payment**

- 4.1 Goods must be paid for at the time of order unless credit is granted at our discretion.
- 4.2 Where credit is granted payment in full must be made within 30 days of invoice date. No discount will be given for early payment.
- 4.3 Where progress payments are agreed term 4.2 will apply to the final payment instalment.
- 4.4 Goods are despatched on or before the date of invoice and we accept no responsibility for delays in transit.
- 4.5 If any payment is overdue we will be entitled to suspend or cancel work (including despatch) on other orders from the customer without prejudice to any other right or remedy available to us, including the right to receive payment for work already carried out and the right to recover the sum unpaid on any previous order.
- 4.6 The customer will have no right of set-off in respect of any claim against us.

#### **5. Non-Delivery and Shortage**

- 5.1 We will make every reasonable effort to meet quoted despatch dates but we will not be liable to the customer for any loss or damage whatsoever (including consequential loss) caused by a delay in or prevention of despatch of goods. The term "consequential loss" includes, but is not limited to, loss of profit, loss of production, loss or use of revenue, cost of capital, loss of or damage to property or equipment, and loss of reputation.
- 5.2 The customer will be deemed to have accepted delivery of goods referred to in any invoice or advice note unless the customer makes a claim to us within 21 days from the date of the invoice or advice note, except when part of the goods referred to therein are received by the customer, in which case any claim with respect to the goods not received in accordance with the invoice or advice note must be made within three days of the short delivery.
- 5.3 We will not accept liability for any damage to goods while in transit at our risk or other discrepancies between invoice particulars and goods received unless such damage or discrepancy is reported to us within three days of receipt of the goods.

#### **6. Warranty**

- 6.1 We warrant goods of our own manufacture against defective workmanship and materials which have substantially diminished or are likely to substantially diminish the life or functionality of the goods for a period of twelve months from the date of despatch. During that time, we will at our option either replace or repair any such goods or parts of goods which are proven defective in these respects up to the value of a new replacement good (or goods).

- 6.2 We accept no liability for damage to or defects in our goods that arise from the improper use, improper handling, and lack of maintenance or any unauthorised modifications made by the customer.
- 6.3 We will make every effort to ensure that our goods comply with their descriptions in our current publications, but subject to these terms no warranty is made as to their exact description, merchantable quality or fitness for purpose.
- 6.4 Any parts not of our manufacture incorporated in our goods or sold by us carry their manufacturer's warranty only, if any.
- 6.5 Apart from the express warranty in Term 6.1 and to the full extent permitted by law, we will be under no liability to the customer (whether in contract, tort or otherwise), for any injury, loss or damages (including but not limited to incidental, special, consequential or general damages) in connection with or arising out of the supply or use of goods howsoever arising, whether or not caused by the negligence of us, our employees or agents. The term "consequential damages" includes, but is not limited to, loss of profit, loss of production, loss or use of revenue, cost of capital, loss of or damage to property or equipment, and loss of reputation.
- 6.6 In no event, regardless of the form of the claim or cause of action (whether based in contract, infringement, negligence, strict liability, or otherwise), shall our liability to the customer and/or its customers exceed the price paid by the customer for the specific goods giving rise to the claim or case of action, and the customer indemnifies us for any damages exceeding the price paid by the customer for those goods.
- 6.7 Goods returned to us subject to a claim under warranty will be accepted on the condition that, should the claim be rejected, all costs incurred including transport to and from our premises and inspection will be to the customer's account.

## **7. Cancellation**

- 7.1 We cannot accept cancellation of orders for goods made, or to be made, specially to a customer's requirements or for goods which we order specially to fill a specific order. Amendments to orders for goods made specially to a customer's requirements may only be made with our express written agreement.

## **8. Return of Goods**

- 8.1 Any goods which have been supplied in accordance with a customer's order but which are subsequently returned will only be credited provided that our prior written agreement to the return of the goods has been obtained. When we agree to returns we will charge a restocking fee of 15% of our invoiced price for the goods except that none specially manufactured, specially ordered, or products modified to a customer's requirements will be accepted for credit.

## **9. Confidentiality**

- 9.1 All drawings, designs, specifications and other information which we supply in connection with a quotation or order are confidential. They remain our property and must not be disclosed to any third person without our written permission and the customer accepts that any such disclosure is likely to cause damage to our business which we will be entitled to recover from the customer.

## **10. Tests**

- 10.1 If the customer requires any goods to be specially tested before despatch, arrangements may be made with us for us to carry out the testing at the customer's expense. Our applicable test and manufacturing standards will apply to the testing unless otherwise agreed.

## **11. On-Site Installation**

- 11.1 The customer will indemnify us against all loss and damage suffered by us, and against all claims and demands made against us, in respect of any injury or damage to persons or property caused by dangerous premises or equipment of the customer.
- 11.2 Installation by us shall not postpone the passing of risk in the goods.

## **12. Industrial Property Right**

- 12.1 If goods supplied by us to the customer's design or specifications infringe or are alleged to infringe any patent or registered design rights or copyright the customer will indemnify us against all damages and costs incurred by us as a result of the infringement or allegation. The customer will provide to us every assistance in meeting an infringement claim brought against us.

## **13. General**

- 13.1 Our failure to enforce or exercise, at any time or for any period of time, any term of any contract incorporating these terms and conditions will not constitute, and will not be construed as, a waiver of such term and will in no way affect our right later to enforce or exercise it.
- 13.2 The invalidity or unenforceability of any of these terms and conditions will not affect the enforceability of the remainder of these terms and conditions.
- 13.3 These terms and conditions will in all respects be construed and have effect according to Australian law and the parties agreed to submit to the jurisdiction of the appropriate Australian Courts.